

MB Amber LED Series

LED Round Flat Top Mini Bollard Amber



MB Amber LED Series

SPECIFICATIONS

- Extruded Aluminum Housing with Flush Mounting Base
- Full Cut Off
- Clear Polycarbonate Lens
- Bronze, White or Black Powder Coat Finish, Optional Custom Color
- CRI LED Aluminum Substrate Board
- Universal Volt LED Driver 120-277V, Optional 480V
- Monochromatic Amber LED Light
- Turtle Friendly, LEDs Operates Between 585 Nanometers and 595 Nanometers
- Optional Surge Protection
- Optional Dimming
- 50,000 Hour Life with 3 Year LED Warranty

APPLICATIONS

- General Area/Pathway Lighting
- Entries, Walkways, Pathways, Area
- Schools, Hospitals, Office, Commercial Buildings
- Ingress/Egress, Campuses

ELECTRICAL

- 120-277V; 50/60Hz
- Optional 480V; 50/60Hz
- 15 Watts; 172 Lumens
- 11 Watts; 100 Lumens

INSTALLATION

- Bolt to Concrete Base or Use Direct Bury Base Option

CERTIFICATIONS/LISTINGS

- CSA Listed
- IP66
- Listed for Wet Locations



PROJECT _____ TYPE _____

QTY _____ NOTES _____ APPROVAL _____

ORDERING/SPECIFYING INFORMATION:

EXAMPLE: MB L 15 TFL UNV BZ

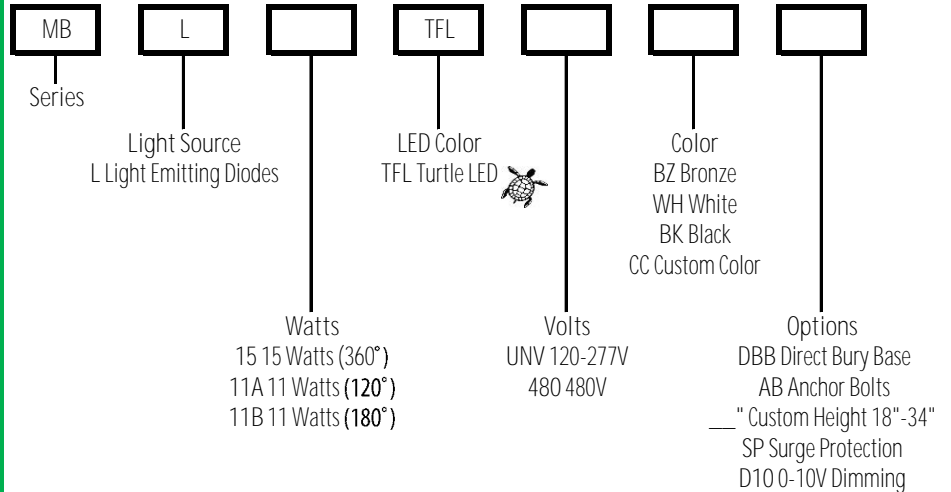

SPECIFICATIONS



DBB Direct Bury Base

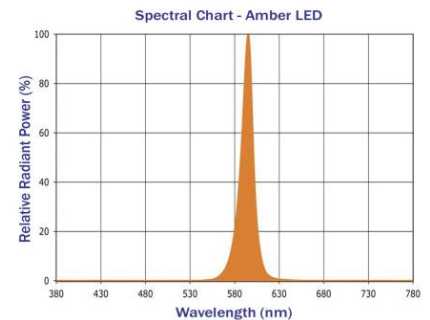

OPTIONS/ACCESSORIES



AB Anchor Bolts

Specifications Subject to Change

