

IP Amber LED Series

LED Industrial Pendant Mount Amber



IP Amber LED Series

SPECIFICATIONS

- Heavy Duty Die Cast Aluminum Housing
- Gray Powder Coat Finish, Optional Custom Color
- Clear Tempered Flat Glass Lens
- CRI LED Aluminum Substrate Board
- Universal Volt LED Driver 120-277V
- Monochromatic Amber LED Light
- Turtle Friendly, LEDs Operates Between 585 Nanometers and 595 Nanometers
- Optional Reflector or Angled Reflector
- Optional Round or Square Swivel Mount
- Optional Goose Hook Large or Small
- Optional Dimming

APPLICATIONS

- General Area Lighting
- Industrial Plants, Public Transportation
- Commercial Walkways, Weather Exposed Areas
- Institutional, Vandal Resistant, Loading Docks

ELECTRICAL

- 120-277V; 50/60Hz
- 23 Watts; 1,194 Lumens

INSTALLATION

- 3/4" NPS for Pendant Mount, Conduit by Others
- Optional Wall Mount with Goose Hook

CERTIFICATIONS/LISTINGS

- CSA Listed
- IP66
- Listed for Wet Locations



PROJECT _____ TYPE _____

QTY _____ NOTES _____ APPROVAL _____

ORDERING/SPECIFYING INFORMATION:

EXAMPLE: IP L 23 TFL UNV

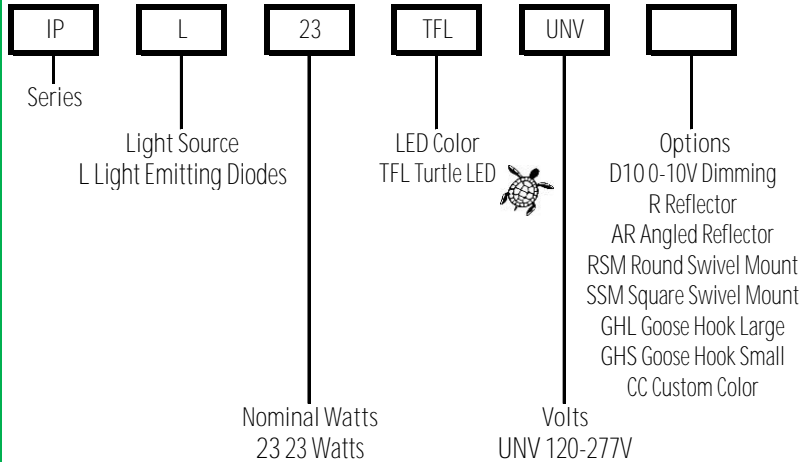

SPECIFICATIONS

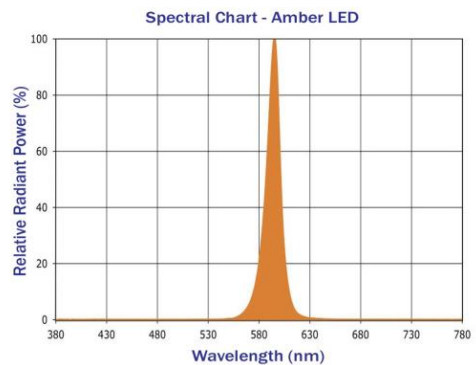
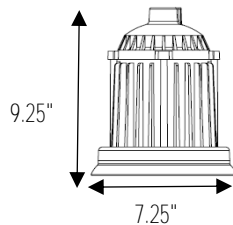

OPTIONS/ACCESSORIES



R Reflector



AR Angled Reflector



RSM Round Swivel Mount



SSM Square Swivel Mount

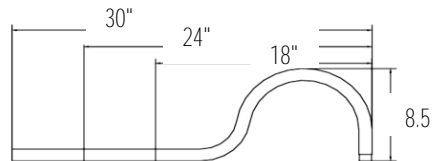

GHS Goose Hook Short

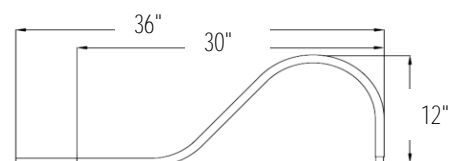

GHG Goose Hook Long

Specifications Subject to Change

