

ESHB LED Series

LED Economy Slim High Bay



ESHB LED Series

SPECIFICATIONS

- Die Cast Aluminum Housing
- Black or White Powder Coat Finish
- Choice of 60° or 90° Lens
- CRI LED Aluminum Substrate Board
- Universal Volt LED Driver 120-277V, Optional 480V
- 4K or 5K LED Color Options
- Instant-On with No Warm-Up
- 6' Power Cord Included
- Integral Heat Sinking
- Optional Dimming
- Optional Surface Mount Kit
- Optional Pipe Adapter for 3/4" NPS

APPLICATIONS

- General Area Lighting
- Warehouses, Distribution Centers, Grocery Stores
- Gymnasiums and Recreational Facilities
- Service Repair Centers and Industrial Facilities

ELECTRICAL

- 120-277V; 50/60Hz
- Optional 480V; 50/60Hz
- 100 Watts; 13,800 Lumens
- 150 Watts; 20,800 Lumens
- 200 Watts; 27,200 Lumens
- 240 Watts; 32,300 Lumens

INSTALLATION

- Mounts with a Hook, Surface Mount Kit or a Pipe Adapter for 3/4" NPS

CERTIFICATIONS/LISTINGS

- UL Listed
- IP65
- Listed for Wet Locations



PROJECT _____ TYPE _____

QTY _____ NOTES _____ APPROVAL _____

ORDERING/SPECIFYING INFORMATION:

EXAMPLE: ESHB 150 60D 40K UNV

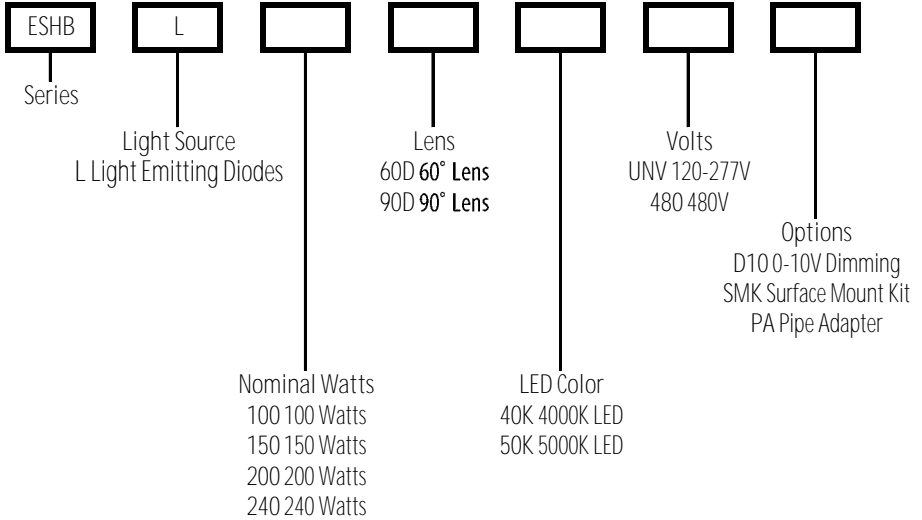

SPECIFICATIONS

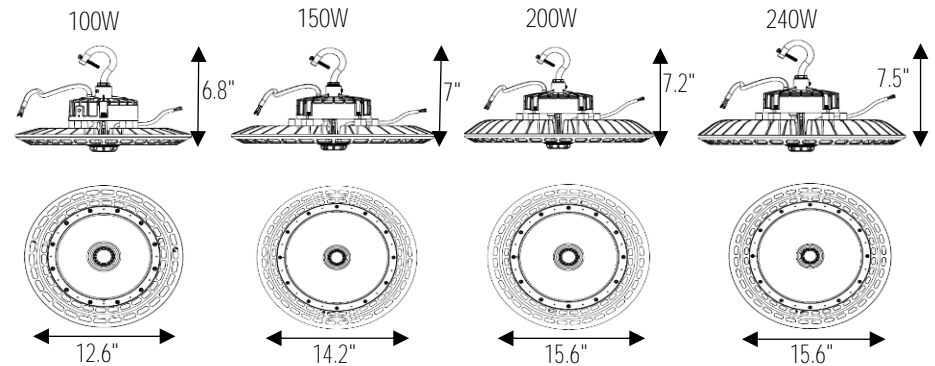

OPTIONS/ACCESSORIES

SMK Surface Mount Kit

PA Pipe Adapter for 3/4" NPS



Specifications Subject to Change

