



**WPI Series**

**SPECIFICATIONS**

- Die Cast Aluminum Housing
- Prismatic Borosilicate Glass Lens
- Aluminium Reflector
- Bronze Powder Coat Finish, Optional Custom Color
- HID Porcelain Medium Base 4KV Socket or CF Plug-In Type, GX24Q
- Multiple Light Source Options
- Optional Emergency Battery (CF)
- Optional Surge Protection

**APPLICATIONS**

- General Area, Facade Lighting, Entry Lighting
- Platforms, Walkways, Parking, Tunnels
- Schools and Universities
- Commercial, Warehouse, Industrial Facilities

**ELECTRICAL**

- 120V: HPS 35W, 50W & 70W
- 120-277V: CF 26W, 32W, 42W, 52W, 64W & 84W
- Quad Volt: HPS & MH 50W & 70W

**INSTALLATION**

- Mounts Over Recessed Box or with Surface Conduit

**CERTIFICATIONS/LISTINGS**

- CSA Listed
- Listed for Wet Locations



PROJECT \_\_\_\_\_ TYPE \_\_\_\_\_

QTY \_\_\_\_\_ NOTES \_\_\_\_\_ APPROVAL \_\_\_\_\_

**ORDERING/SPECIFYING INFORMATION:**

**EXAMPLE:** WPI M 70 Q L

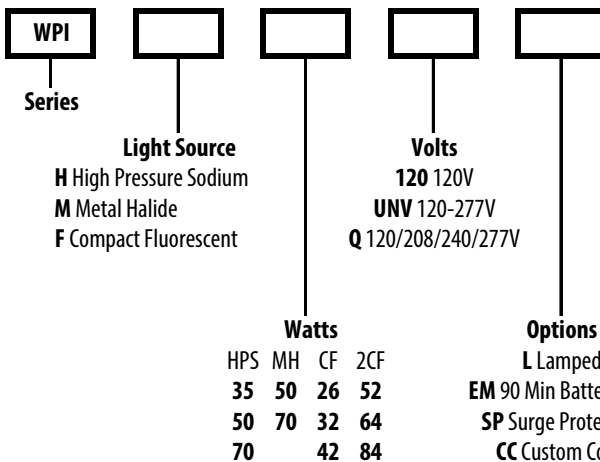

**SPECIFICATIONS**

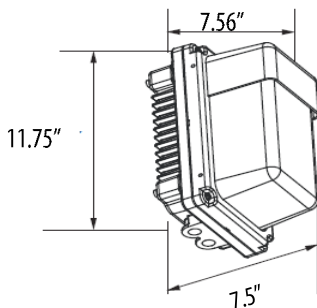

**OPTIONS/ACCESSORIES**

*Specifications Subject to Change*

