

WAM Series

Medium Architectural Wall Pack



WAM Series

SPECIFICATIONS

- Die Cast Aluminum Housing
- Borosilicate Molded Glass Lens
- Bronze Powder Coat Finish, Optional Custom Color
- Internal Aluminum Reflector (Non LED)
- HID Porcelain Medium Base 4KV Socket or CF Plug-In Type, GX24Q (Non LED)
- Stainless Steel Hardware
- Multiple Light Source Options
- 3K, 4K or 5K LED Color Options
- Universal Volt LED Driver with Optional Dimming
- Optional Emergency Battery (CF/LED)
- Optional Photocell
- Optional Surge Protection
- Optional Wire Guard

APPLICATIONS

- General Area, Facade Lighting, Entry Lighting
- Platforms, Walkways, Parking, Tunnels
- Schools and Universities
- Commercial, Warehouse, Industrial Facilities

ELECTRICAL

- 120-277V: LED 37W & CF 26W, 32W, 42W, 52W, 64W & 84W
- 120V: HPS 35W, 50W, 70W, 100W & 150W
- Quad Volt: HPS 50W, 70W, 100W & 150W
- MH 50W, 70W & 100W & 150W

INSTALLATION

- Mounts Over Recessed Box or with Surface Conduit

CERTIFICATIONS/LISTINGS

- CSA Listed
- Listed for Wet Locations



PROJECT _____ TYPE _____

QTY _____ NOTES _____ APPROVAL _____

ORDERING/SPECIFYING INFORMATION:

EXAMPLE: WAM M 100 Q L

WAM						
Series	Light Source	LED Color		Options		
M Metal Halide	H High Pressure Sodium	___ Non LED		EM 90 Min Battery (CF/LED)		
F Compact Fluorescent	L Light Emitting Diodes	30K 3000K LED		D10 0-10V Dimming (LED)		
		40K 4000K LED		SP Surge Protection		
		50K 5000K LED		PC Photocell		
				WG Wire Guard		
				CC Custom Color		
		Watts		Volts		
		MH	HPS	CF	2CF	LED
		50	35	26	52	37
		70	50	32	64	
		100	70	42	84	
		150	100			
						150
						120 120V
						UNV 120-277V
						Q 120/208/240/277V

SPECIFICATIONS

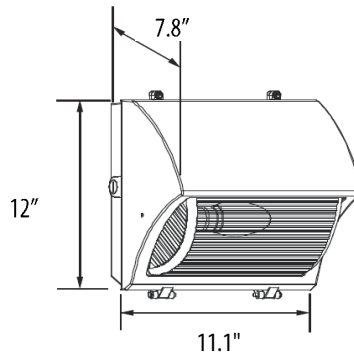

OPTIONS/ACCESSORIES

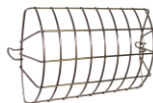

WG Wire Guard



Specifications Subject to Change